

# Dispenser 3RD12

Votre interlocuteur :

**SYNEO**  
 GROUPE SUPRATEC

## Description



This compact ViscoTec dispenser achieves a precise, consistent and reliable dosing of widely varying media. Thanks to the special rotor-stator geometry, a valve to prevent medium from automatically flowing out is not required. Alternately opening chambers allow the gentle transfer and pulsation-free dispensing of product.

- Dosing volume: 1,7 ml/rev
- Non-stick coated interior
- Reverse-flow possible (no dripping or stringing of product)
- Connection between dispensed quantity and speed is absolutely linear
- Constant dosing volume, also with density or viscosity fluctuations
- Reliable dosing even without heating the medium
- Low maintenance
- Clamp system for quick dismantling
- As ViscoPro dosing system: easy programming of quantity and speed (see separate data sheet)

## Application

- Dot or bead application, variable quantities possible
- Suitable for all adhesives and sealants
- For low to high-viscosity media
- Particularly suitable for abrasive, high-content or shear sensitive media

## Technical data

|                            |                  |
|----------------------------|------------------|
| Dosing volume              | ~ 1,7 ml/rev     |
| Flow rate                  | 12 - 270 ml/min* |
| Minimum dosing quantity    | 0,1 ml*          |
| Operating temperature      | +10 to +100 °C   |
| Temperature of medium      | -20 to + 100 °C  |
| Maximum speed              | 150 rpm*         |
| Maximum permissible torque | 8 Nm             |
| Maximum dosing pressure    | 20 - 30 bar*     |
| Supply (input) pressure    | max. 10 bar*     |
| Weight                     | ca. 1400 g       |

\* depending on medium



### Fabricant

 ViscoTec Pumpen- u. Dosiertechnik GmbH  
 mail@viscotec.de • www.viscotec.de

**SYNEO**  
 GROUPE SUPRATEC

 Agence en France : **SYNEO - GROUPE SUPRATEC**  
 ZI La Marinière - rue Charles de Gaulle  
 91070 Bondoufle  
 Tél. : +33 (0)1 69 11 81 75  
 infocolle@syneo.net - www.SYNEO.net

## Item number

|                      |        |
|----------------------|--------|
| 3RD12-H with EPDM(p) | 128117 |
| 3RD12-H with VisChem | 121645 |
| 3RD12-H with VisTon  | 126627 |
| 3RD12-L with EPDM(p) | 115582 |
| 3RD12-L with VisChem | 122774 |
| 3RD12-L with VisTon  | 129276 |

## Cross section

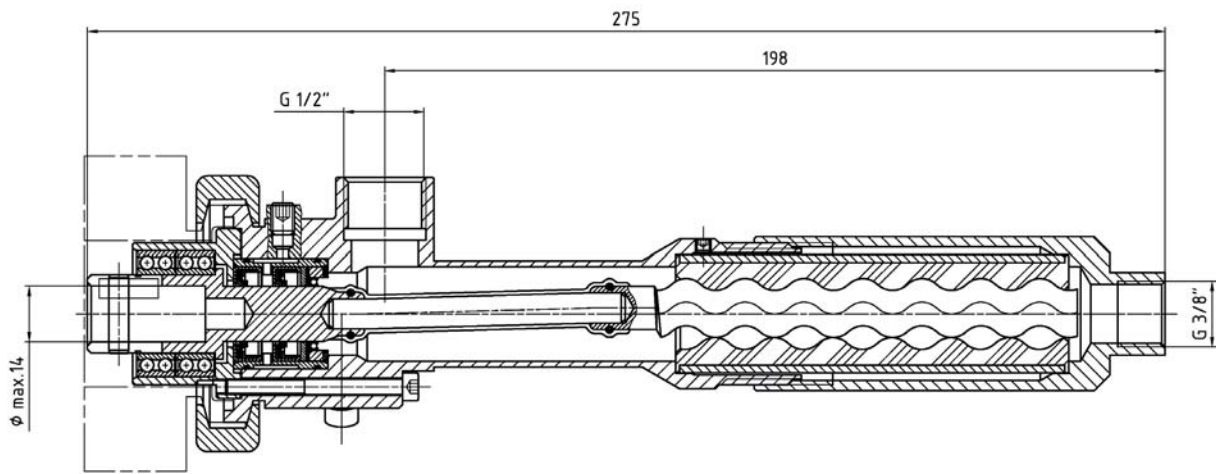

Errors and omissions excepted

## Application examples



**Fabricant**

ViscoTec Pumpen- u. Dosiertechnik GmbH  
mail@viscotec.de • www.viscotec.de



Agence en France : **SYNEO - GROUPE SUPRATEC**  
ZI La Marinière - rue Charles de Gaulle  
91070 Bondoufle  
Tél. : +33 (0)1 69 11 81 75  
infocolle@syneo.net - www.SYNEO.net